

LYNX™ Silicon Photomultiplier Module LynX-A-33-W50-T1-X



LYNX™

Excelitas' LynX™ Silicon Photomultiplier Module (LynX-A-33-W50-T1-X) delivers high responsivity, high dynamic range, high linearity and an excellent S/N ratio, as compared to traditional PMTs and other SiPM solutions.

Excelitas' LynX™ Silicon Photomultiplier Module series is a compact, easy-to-use, analogue low light level detection (L³D) module employing Excelitas' leading-edge C30742 Series Silicon Photomultiplier (SiPM) chip in a hermetic TO-8 package with thermoelectric cooler, a stable voltage power supply circuit, and a low noise transimpedance amplifier.

With this compact voltage output module, the preamplifier gain is optimized to obtain maximum dynamic range and linearity with the SiPM at pre-set operating voltage. It outperforms other SiPM solutions in key performance parameters such as higher photon detection efficiency (PDE) and better signal-to-noise ratio across the full 400 nm - 900 nm wavelength spectrums.

The LynX™ SiPM module is offered as a standard, commercial- off-the-shelf (COTS) product. It contains a 3x3 mm² active area SiPM with 50x50 μm² microcells for optimum fill factor and PDE. It has two standard bandwidths: 1MHz and 10MHz, with either AC or DC coupled output options. The module is fully ROHS compliant. Power cable for the module is available as well as a 1mmx1mm chip configuration module.

In addition to our standard, off-the-shelf SiPM module, Excelitas also offers customized modules tailored from our standard designs. Depending upon customer requirements, modifications can include bandwidth optimization, FC-connectorized packaging, photon counting digital output, and customized testing.

Key Features

- High responsivity:
 - 0.75 V/nW @ 525 nm (typ.)
 - 0.4 V/nW @ 700 nm (typ.)
- Excellent signal to noise ratio as compared to traditional PMTs
- High dynamic range and linearity
- Low NEP
- Built-in TE cooler
- Compact and user-friendly
- ROHS-compliant

Applications

- Fluorescence measurement
- Analytical instrumentation
- Flow Cytometry

LynX-A-33-W50-T1-X

LYNX™ Silicon Photomultiplier Module

Table 1. Electro-optical characteristics

Test conditions: Case temperature = 22°C, $V_{in} = +5V$, $R_L = 50\Omega$ DC coupled

Detector					
Parameter	Condition	Min.	Typ.	Max.	Unit
Effective Active Area			3 x 3		mm
Num. Of Microcells			3600		
Microcell Size			50 x 50		μm
Spectral Bandwidth		350		950	nm
Peak Wavelength			500		nm
Module					
Parameter	Condition	Min.	Typ.	Max.	Unit
Positive Supply Voltage		4.5	5.0	5.5	V
Positive Supply Current			350	1000	mA
Power Up Settling Time			15		s
Output Voltage Swing	High impedance			+5	V
Responsivity	@525 nm in 50 Ohm		0.75		V/nW
Bandwidth		1	1.5		MHz
NEP			1.0		$fW/(Hz)^{1/2}$
Output offset voltage			1.5		mV
Storage Temperature		-10		+50	°C
Operating Temperature		+5		+50	°C

Table 2: Ordering Guide

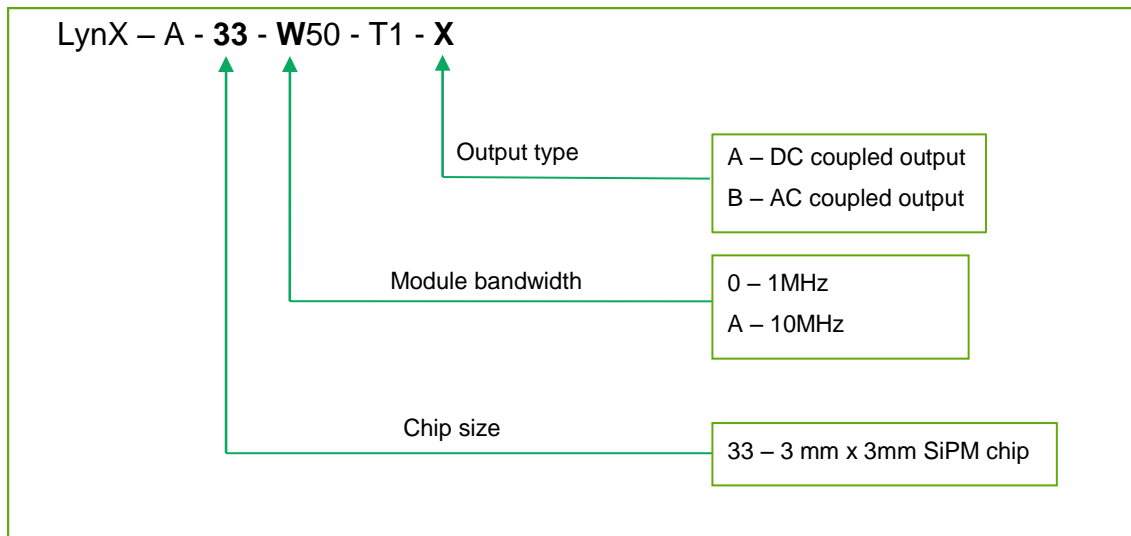

Figure 1 : Performance

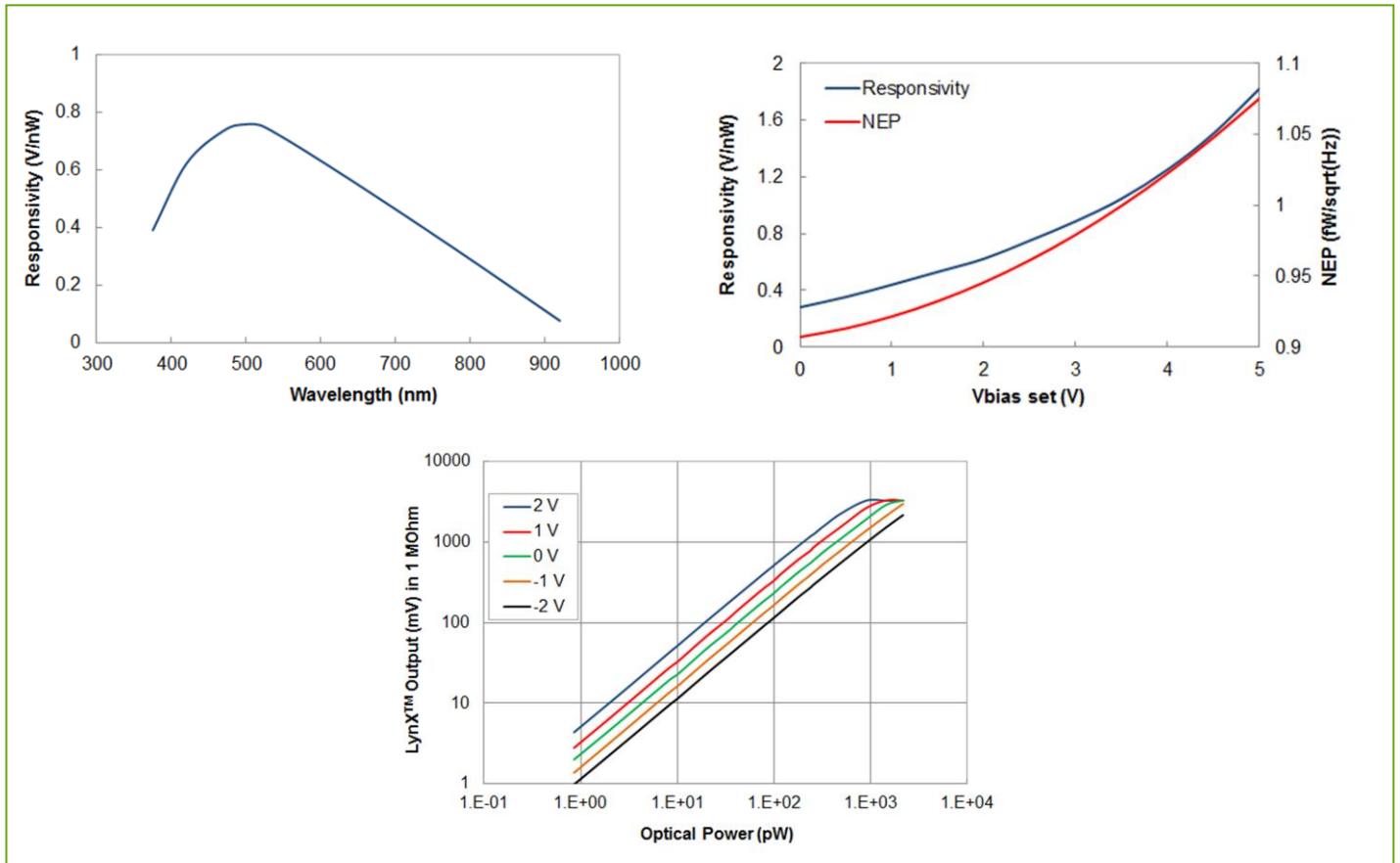
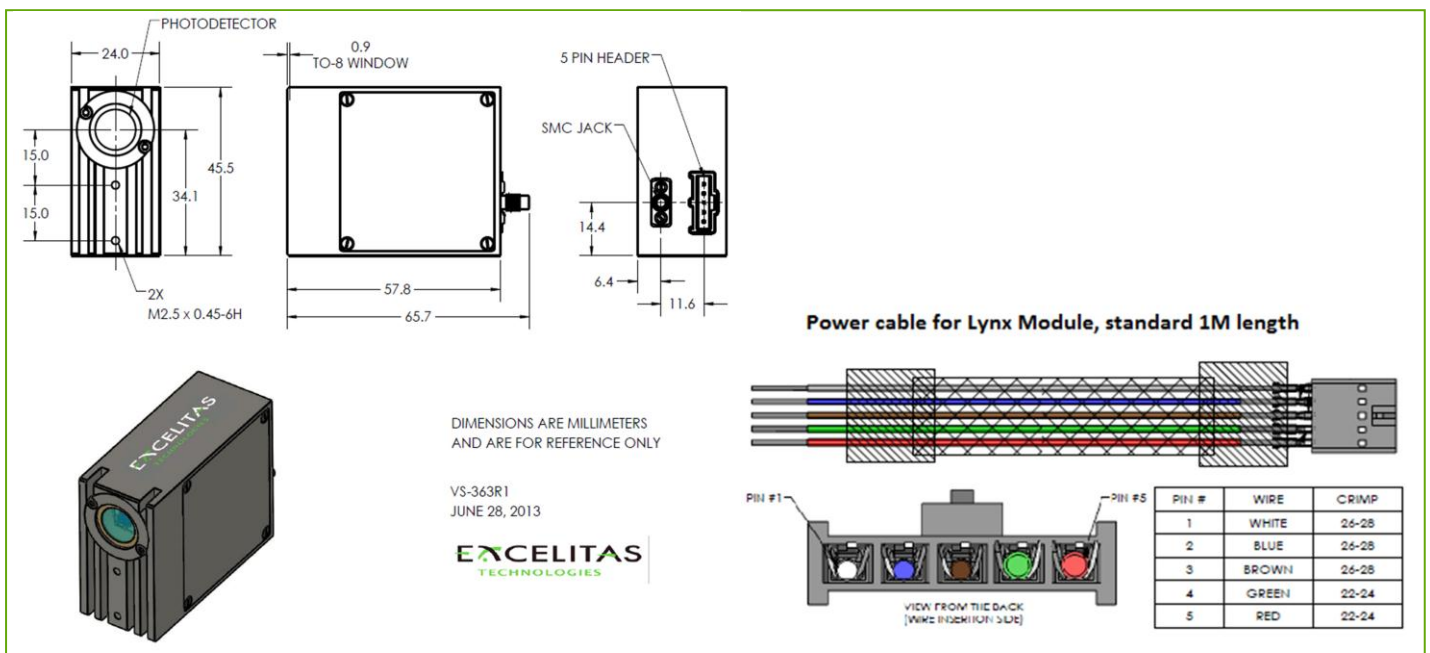

Figure 2: Physical Configuration



LynX-A-33-W50-T1-X

LYNX™ Silicon Photomultiplier Module

Figure 3: SiPM Block Diagram and Module Pin-out

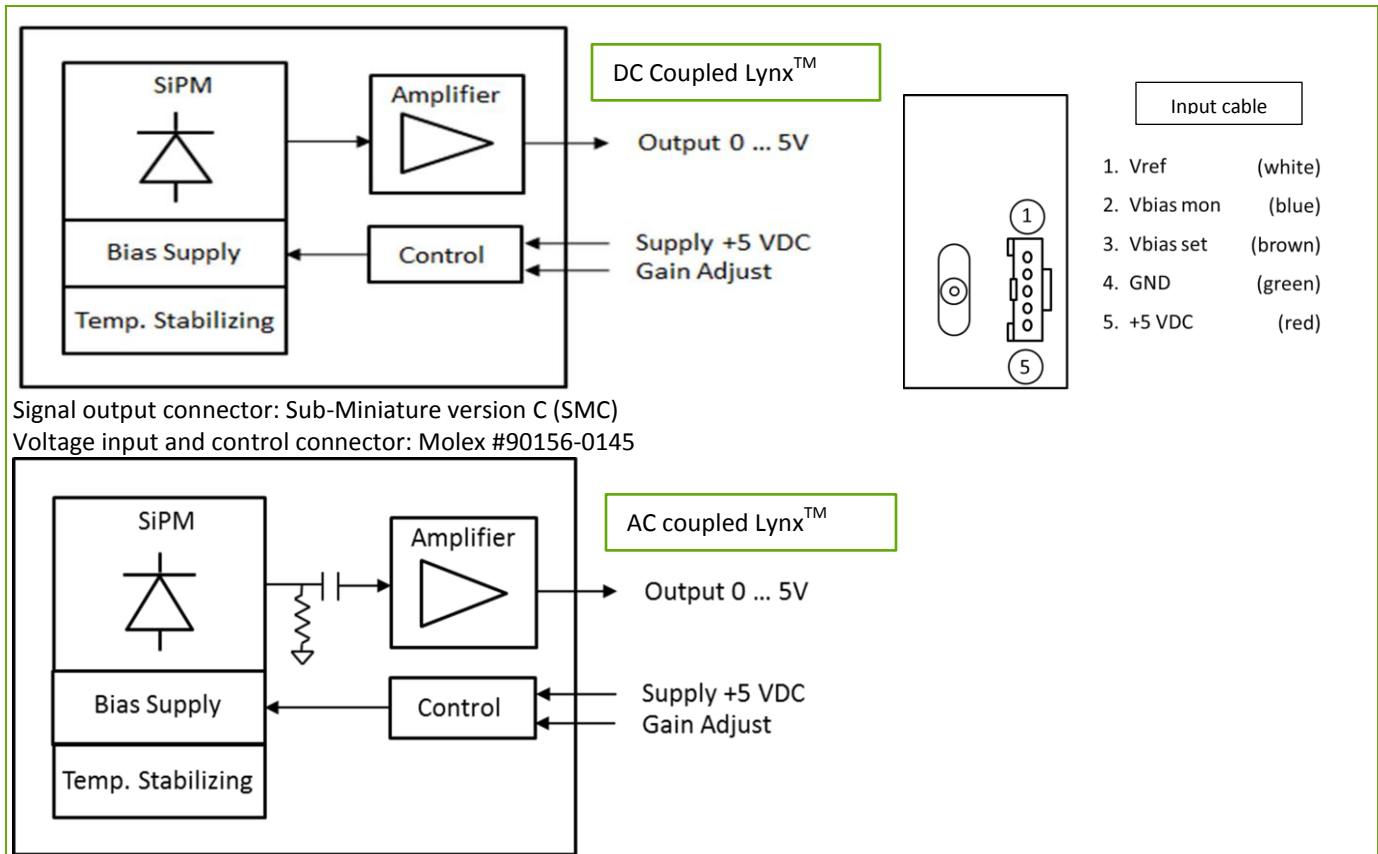

RoHS Compliance

This series of APDs are designed and built to be fully compliant with the European Union Directive 2011/65/EU – Restriction of the use of certain Hazardous Substances (RoHS) in Electrical and Electronic equipment.



Excelitas Technologies' Silicon Photomultiplier development program is supported by financial contribution of the Government of Canada.

About Excelitas Technologies

Excelitas Technologies is a global technology leader focused on delivering innovative, customized solutions to meet the detection, lighting, and other high-performance technology needs of OEM customers. From medical applications to analytical instrumentation, clinical diagnostics, industrial, safety and security, and aerospace and defense applications, Excelitas Technologies is committed to enabling our customers' success in their end-markets. Excelitas Technologies has approximately 5,000 employees in North America, Europe and Asia, serving customers across the world.

Excelitas Technologies
22001 Dumberry Road
Vaudreuil-Dorion, Quebec
Canada J7V 8P7
Telephone: (+1) 450.424.3300
Toll-free: (+1) 800.775.6786
Fax: (+1) 450.424.3345
detection.na@excelitas.com

**Excelitas Technologies
GmbH & Co. KG**
Wenzel-Jaksch-Str. 31
D-65199 Wiesbaden
Germany
Telephone: (+49) 611 492 430
Fax: (+49) 611 492 165
detection.europe@excelitas.com

Excelitas Technologies Singapore, Pte. Ltd.
8 Tractor Road
Singapore 627969
Telephone: (+65) 6775 2022 (Main number)
Telephone: (+65) 6770 4366 (Customer Service)
Fax: (+65) 6778-1752
detection.asia@excelitas.com

For a complete listing of our global offices, visit www.excelitas.com/locations

EXCELITAS
TECHNOLOGIES

© 2014 Excelitas Technologies Corp. All rights reserved. The Excelitas logo and design are registered trademarks and LynX is a trademark of Excelitas Technologies Corp. All other trademarks not owned by Excelitas Technologies or its subsidiaries that are depicted herein are the property of their respective owners. Excelitas reserves the right to change this document at any time without notice and disclaims liability for editorial, pictorial or typographical errors.