

DigiPyro[®] PYQ 2898

How to use Triple Channel DigiPyro[®]
Basics - Application - Advantages

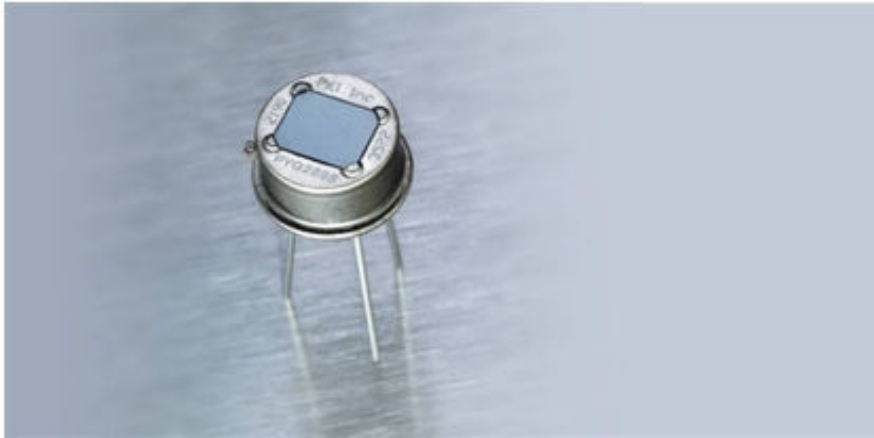

Introduction

The Triple Channel, PYQ 2898, is the newest addition to the growing DigiPyro[®] family of digital pyroelectric infrared detectors, brought to you by Excelitas. The Triple Channel Quad Element detector is the high end version of the DigiPyro[®] family, with two pairs of elements representing two channels and an additional temperature reference channel. It is a quad element configuration which is connected to a special integrated circuit. It contains the analog-to-digital converter, a temperature sensor, the low-power oscillator and a serial interface, all in a standard three-pin TO-5 housing. It offers a 42 bit "direct link" interface.

The move from analog to digital technology enables the DigiPyro[®] to deliver a number of advantages including space savings from fewer components and significantly improved EMI immunity. With the addition of the PYQ 2898 to the DigiPyro[®] family, Excelitas is making another step-change in digital motion detection, for the first time enabling low-cost, quad element systems.

Features and Benefits

- ▶ Digital output pyrodetector 42 bit output "direct link", including temperature reference
- ▶ Three-pin TO-5 housing
- ▶ Low-cost, quad element configuration Four elements 1.375 x 1 mm² 0.8 / 0.25 mm spacing
- ▶ Infrared window
- ▶ 5.5..14 μm transmission
- ▶ Window size 5.2 x 4.2 mm²
- ▶ Outstanding electrical performance
- ▶ Low EMI sensitivity
- ▶ Unique responsivity
- ▶ High power rejection rate
- ▶ RoHS compliant

Applications

- ▶ Intrusion alarm applications
- ▶ Motion activated light switches
- ▶ Door openers

Authors:

Hartmut Jesch
Wolfgang Schmidt
Fred Plotz
Gerhard Knaup
Harald Thomas
Thomas Kastner

Excelitas Technologies
Wenzel-Jaksch-Str. 31
65199 Wiesbaden
Germany

Phone: +49-611-492-247
Fax: +49-611-492-170

E-mail:
Generalinquiries.Europe@excelitas.com

Table of Contents

Introduction	1
Features and Benefits	1
Applications	1
Definition	3
Electrical Configuration	3
From Analog to Digital	3
Digital Zero Signal Line	4
Out of Range Feature	4
Data Communication	4
Interrupt Driven Read Out	6
Electrical Data	8
Typical Responsivity vs. Frequency	8
Software Filter Recommendation	9
Physical Configuration	9
Operating and Handling	11
Frequently Asked Questions	12

Definition

Element: is a sensing surface with a defined size. As all units work with optics, this element and the optics will determine the performance.

Channel: means an individual detector. When there are two channels, this means two individual detectors or two individual outputs.

Quad Element Configuration: Describes two pairs of pyroelectrical elements in a square shape, providing two separate signal information.

Detector / Sensor: A detector gives a pure output signal; the sensor has a processed signal output.

DIRECT LINK interface: The *DIRECT LINK* is the interface between DigiPyro® and any micro controller. It is a bidirectional single wire connection specially designed for this application.

Data Rate: The refresh time of data (availability of new data block).

Resolution: Analog value of one count.

Clock Time: 1/Internal Clock frequency (the frequency of internal command processing).

Electrical Configuration

The DigiPyro® PYQ 2898 consists of quad element configuration, which is connected to a special integrated circuit. It contains the analog-to-digital converter, a temperature sensor, the low-power oscillator and a serial interface. The functional block diagram is shown below.

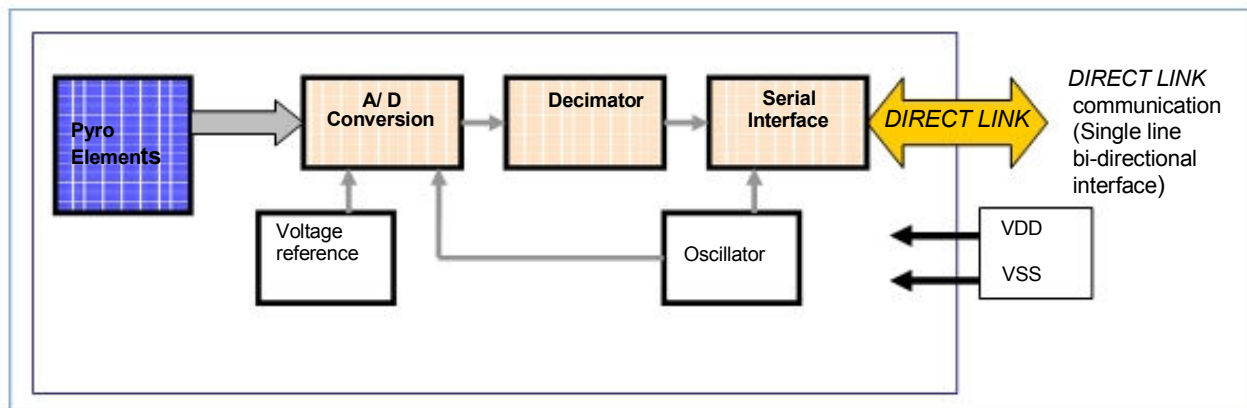

Figure 1: Block diagram of DigiPyro®

From Analog to Digital

The DigiPyro® series is the first pyroelectric detector family to display information in bit form compared to mV signals of analog detectors. For all those engineers being used to lay out their systems in respect to such analog signals we hereby give some rough comparison:

Resolution: 1 Counts \triangleq 6.5 μ V
 Range: 0 to 16383 Counts \triangleq 0 to 107.2 mV
 DC Offset: 8192 Counts \triangleq 53.6 mV typical
 Noise: 6 Counts \triangleq 39 μ V (with bandpass)

Digital Zero Signal Line

As the pyroelectric effect generates positive and negative signal amplitudes, the detector circuitry needs an electrical offset to be able to process such signals. The internal voltage reference provides for this offset. As to the user this offset appears as a digital zero line which ranges at 8192 Counts and may differ in series from one part to the next. To recognize the zero line of the individual detector, the user may either use a digital bandpass or subtract the measured offset from the signal. To do so, the detector shall be covered from incident radiation and protected from possible air drafts and indirect radiations. Then the detector output shall be monitored. Now the signal represents the individual zero line. When the reading is stabilized, this value can be taken and stored in the user's μ Processor as the detectors zero line.

Out of Range Feature

To avoid saturation of the detector, the DigiPyro[®] includes a special out of range detection feature. It detects when the detector runs into saturation caused by temperature shock. This happens e.g. when touching the detector with warm hands. The special feature of the digital detectors is to shorten the input of the circuit for duration of 512 system clocks when it monitors the digital values rising above 15872 Counts or falling below 511 Counts. If this re-occurs, the input is shortened repeatedly until this thermal shock problem has expired.

Data Communication

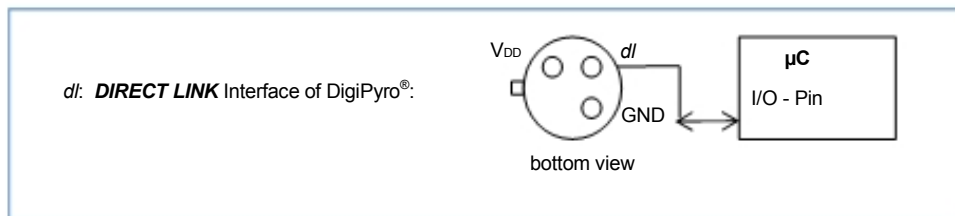

Figure 2
DigiPyro[®] connections

The serial interface has a 42 Bit binary output format splitting up into temperature and the two element pair information; each coded in 14 Bit. The *DIRECT LINK* pin is used as bidirectional data output and clock input.

The following diagram shows the communication signal flow:

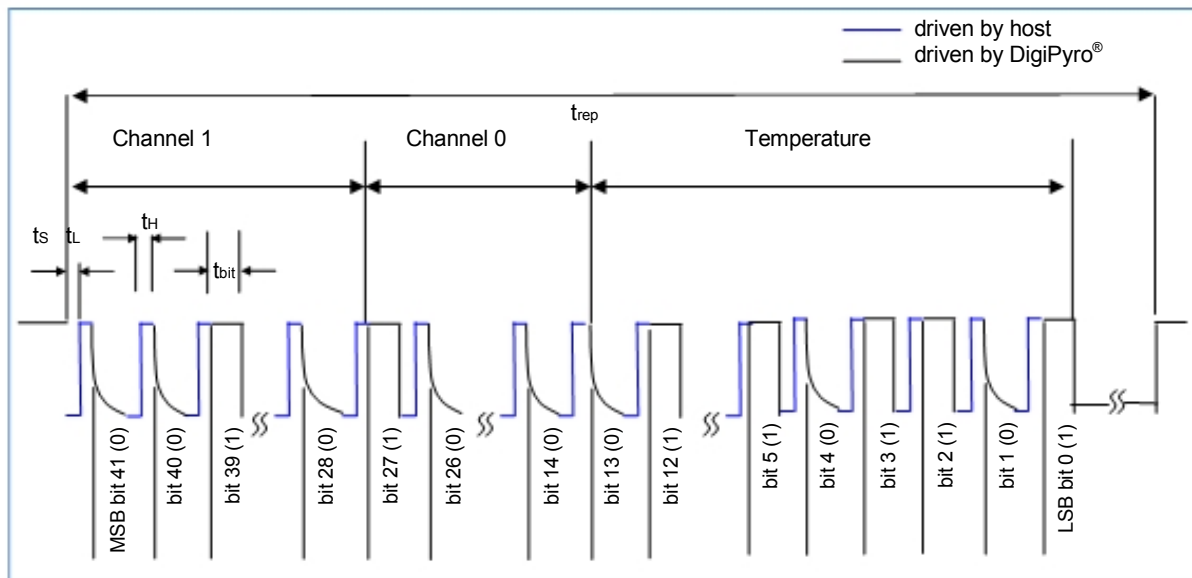

Fig. 3: Communication timing: channel 1, channel 0, temperature

The serial interface has a 3 x 14 bit binary output format (Channel 1, Channel 0, Temperature) which allows a physical data value range from 0 ... 16383 for each channel. The *DIRECT LINK* pin is bi-directional data output and clock input. A data transmission cycle (t_{REP}) will start when the ADC has converted a new data value and passed it through the serial interface. DigiPyro® indicates start of transmission by pulling *DIRECT LINK* pin to HIGH.

After setup time (t_s) has passed the DigiPyro® expects a LOW to HIGH transition (t_L, t_H) on the *DIRECT LINK* pin and will subsequently output the data bit state. After Data bit settling time (t_{bit}) the DigiPyro® waits for the next LOW to HIGH transition and the sequence will be repeated until all 42 bits are shifted out. After output of the last bit (bit 0) and corresponding data bit settling time (t_{bit}), the host controller shall force *DIRECT LINK* pin to LOW and subsequently release *DIRECT LINK*. The DigiPyro® will remain with *DIRECT LINK* pin at LOW level until the next signal sample is available at the serial interface and a new transmission cycle starts.

The data bit settling time t_{bit} specified under electrical data is a minimum time. For the LOW level it may vary depending on the capacitive load of the *DIRECT LINK* pin. It is recommended to start host interface implementation with a longer data bit settling time t_{bit} to ensure proper LOW level settling and then reduce t_{bit} empirically to optimize for reliable data transmission at maximum transmission speed.

If data transmission is interrupted during Data Clock Low time (t_L), the serial interface will be updated with a new value if t_L lasts longer than the serial interface update time (t_{REP}). In case of data transmission is continued, false readings may be caused. Therefore data transmission should preferably be interrupted during Data Clock High time (t_H). Interruption shall be kept within the serial interface update time (t_{REP}), otherwise the serial interface will not be updated with new values as long as the *DIRECT LINK* pin is kept HIGH.

If a host reads the serial interface output faster than the update rate of the serial interface (t_{REP}) the data bits are all read as "0". In order to benefit fully from the low noise, the Triple Channel DigiPyro® should be read interrupt driven.

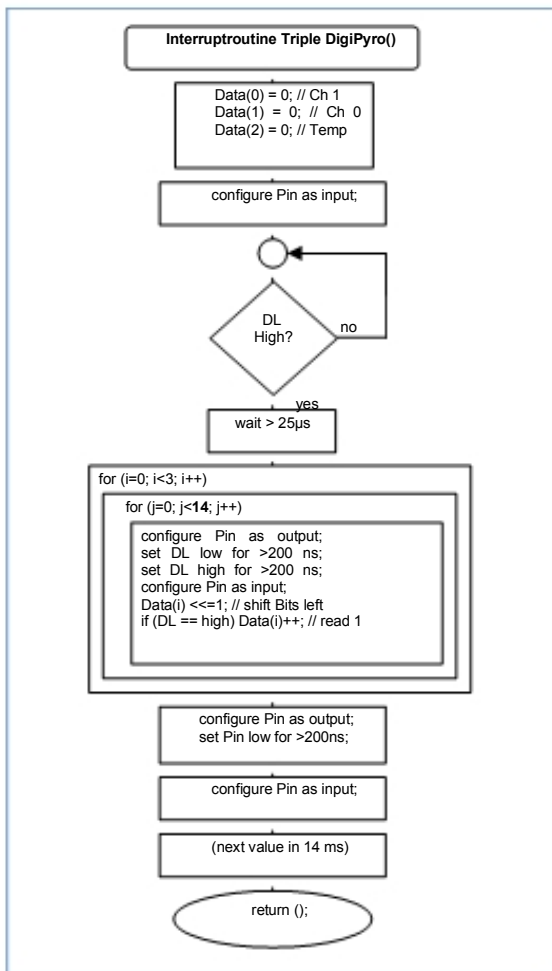

Fig.4: DigiPyro® read out flow chart

Interrupt Driven Read Out

To transfer the above read-out flow chart into a software code, a simple program code in C-language can be applied. (Program code for Atmel® ATmega 8 µC - as I/O- pin port C Bit 0 is used).

```

// DL: Direct Link Interface of the Triple DigiPyro®. A bidirectional single wire interface, //
directly connectable to most µC's I/O- pins.
// V2.03 10.12.2007 read the Triple Channel DigiPyro® synchronous
// µC: Atmel ATmega8, 6MHz: Port C0 (ADC0, Pin 23) connected to Int0 (Pin 32) external Interrupt. //
DPDL High will cause an Interrupt and so start reading the Triple Channel DigiPyro®
// immediately when ADC has finished
// read 3 x 14 Bit from Triple DigiPyro®, 0=Channel 1, 1= Channel 0, 2=Temperature

#include <mega8.h>

// Definitions for DigiPyro Port C Bit 0
#define DDPDL      DDRC.0      // port C bit 0 data direction bit
#define DPDL_OUT  PORTC.0     // port C bit 0 output
#define DPDL_IN   PINC.0      // port C bit 0 input
#define PORT_IS_INP  0
#define PORT_IS_OUTP 1

int Data[3]; // Data[0]: Channel 1, Data[1]: Channel 0, Data[2]: Temperature (triple: 3 x 14 Bit)

// ***
// External Interrupt 0 service routine
//
// read DigiPyro
//

```

```

interrupt [EXT_INT0] void ext_int0_isr(void)

{
    // Disable External Interrupt0 until DigiPyro is read.
    MCUCR &= 0xFC;           // Ext. Interrupt 0 disabled while reading
    digipyro();
    MCUCR |= 0x03;          // Ext. Interrupt 0 enabled
}

// *** *
// function: digipyro()
//
// do not read asynchronous to the ADC- converter. Read the interface interrupt-driven: High = new data //
// this routine should preferably be used by the interrupt routine only.
// use Data[] for access to the DigiPyro after interrupt
// reads DigiPyro data: Data[0]: Channel 1, Data[1]: Channel 0, Data[2]: Temperature

void digipyro(void)
{
    int i, j, k, pir_data;

    pir_data = 0;
    DDPDFL = PORT_IS_INP;    // Configure PORT C0 as Input for
                            // DigiPyro Direct Link Interface (DPDL)

    while(DPDFL_IN == 0);    // wait for DPDL = high - max. 1 ms (in regular mode) //
    for (j=0; j < 60; j++);  // wait appr. 30 µsec (tS)

    for (k = 0; k < 3; k++)   // 3 Channels
    {
        for (i=0; i < 14; i++) // 14 Bits each
        {
            DPDL_OUT = 0;     // Set DPDL = Low, Low level duration must be > 200 ns (tL) //
            DDPDFL = PORT_IS_OUTP; // Configure PORT C0 DPDL as Output
            DPDL_OUT = 0;     // Set DPDL = Low, Low level duration must be > 200 ns (tL) //
            #asm("nop")
            DPDL_OUT = 1;     // Set DPDL = High, High level duration must be > 200 ns (tH) //
            #asm("nop")
            DDPDFL = PORT_IS_INP; // Configure PORT C0 DPDL as Input
            #asm("nop")
            #asm("nop")

            for(j=0; j < 2; j++); // wait appr. 5 µsec to ensure proper low level reading (tbit) //
            pir_data <<= 1;
            if (DPDL_IN) pir_data++; // sample bit
        }
        Data[k] = pir_data;
        pir_data = 0;
    }
    DDPDFL = PORT_IS_OUTP; // Configure PORT C0 DPDL as Output
    DPDL_OUT = 0;          // Set DPDL = Low, Low level duration must be > 200 ns (tL) //
    DDPDFL = PORT_IS_INP; // Configure PORT C0 DPDL as Input
    return ();
}

void main(void)
{
    // Port C initialization
    // Func6=In Func5=Out Func4=Out Func3=Out Func2=Out Func1=In Func0=In
    // State6=T State5=0 State4=0 State3=0 State2=0 State1=T State0=T
    PORTC = 0x00;
    DDRC = 0x3C;

    // External Interrupt initialization
    // INT0: On
    // INT0 Mode: Rising Edge, DigiPyro triggers Interrupt to be immediately read after conversion
    GICR |= 0x40;
    MCUCR &= 0xFC;
    GIFR |= 0x40;

    SFIOR |= 0x04;          // no pullups: PUD=1 (Bit#2)

    #asm("sei")             // Global enable interrupts

    int channel1, channel0, temperature; // DigiPyro data 3 x 14 Bit

    channel1 = Data[0];
    channel0 = Data[1];
    temperature = Data[2];

    // .. your code ..
}

```

Electrical Data

Below there are all required data to operate the detector. Unless specified differently, all data refer to 25°C environmental temperature.

Parameter	Symbol	Min	Typ	Max	Unit	Remarks
Operating voltage	V _{DD}	2.7	3.3	3.6	V	
Supply current 4)	I _{DD}			15	µA	V _{DD} = 3.3V
Input low voltage	V _{IL}			0.2V _{DD}	V	
Input high voltage	V _{IH}	0.8V _{DD}			V	
Pull up / down current			100		µA	Input to V _{SS} / V _{DD}
Data setup time	t _s	25			µs	
Data clock low time	t _L	200			ns	
Data clock high time	t _H	200			ns	
Data bit settling time	t _{bit}	1			µs	C _{LOAD} = 10pF
Serial interface update time	t _{REP}		14		ms	
ADC counts of Bits			42		Bits	
ADC resolution			14		Bits	Max. Count = 2 ¹⁴ -1
ADC sensitivity		6.1	6.5	7	µV/count	
ADC output offset		7000	8192	9200	counts	
Responsivity 1)		3.5	4.5		kV/W	
Match 2)				10	%	
Noise 3)			30	75	µVpp	
Gain temperature 4)			80		Counts/K	-20°C to +80°C
Linearity		-5		5	%	
Internal clock frequency	f _{CLK}		32		kHz	
Operating temperature	T ₀	-40		85	°C	The electrical parameters may vary from specified values accordance with their temperature dependency.
Storage temperature:	T _s	-40		85	°C	Avoid storage under high humid environment.

Table 1: DigiPyro® electrical data

- 1) Responsivity is measured within spectral range 7 - 14 µm as per fig. 5 at 1Hz.
- 2) Electrical balance (match) is measured with same test set up as responsivity, both elements exposed to radiation. A percent value is calculated as $100 \times \frac{S_m}{S}$ / S : S_m : signal (match), S: signal of left or right element.
- 3) After a 10 minute settling time, noise is monitored for the duration of 1500 sec. at a temperature of 25°C, shut from infrared energy, digital filter between 0.4 to 10Hz.
- 4) Values may differ for engineering samples

Typical Responsivity vs. Frequency

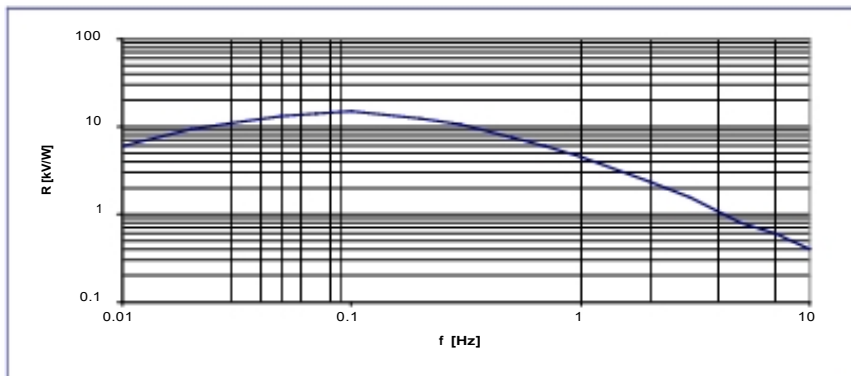

Fig.5: Frequency response

Software Filter Recommendation

The most different feature of DigiPyro® is the direct communication with the hosting microcontroller without any hardware filtering. Thus it is necessary to implement software filters within the host.

Various websites give recommendations for software designed filters. You may check also:

<http://www-users.cs.york.ac.uk/~fisher/mkfilter/>

http://www.atmel.com/dyn/resources/prod_documents/doc2527.pdf

Please note: The above given links are links to external Web sites and thus they are out of Excelitas' control and responsibility. For that reason Excelitas does not guarantee for the accuracy of the content or functions provided by these links.

Physical Configuration

The Triple Channel DigiPyro® is supplied in TO-5 housing with three pins for electrical connection and standard infrared optical window. The drawings below refer to the quad element configuration of type PYQ 2898.

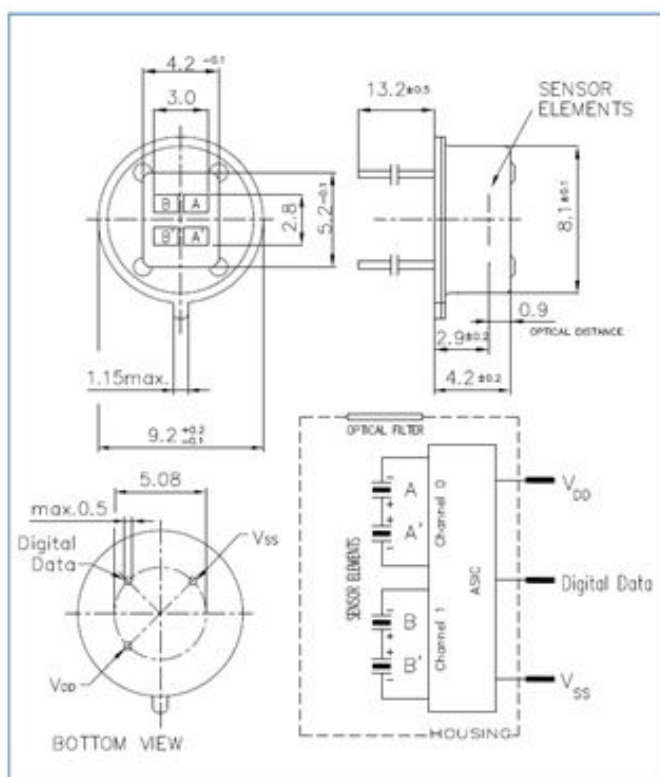

Figure 6

Element configuration of PYQ 2898

Application Circuit Example

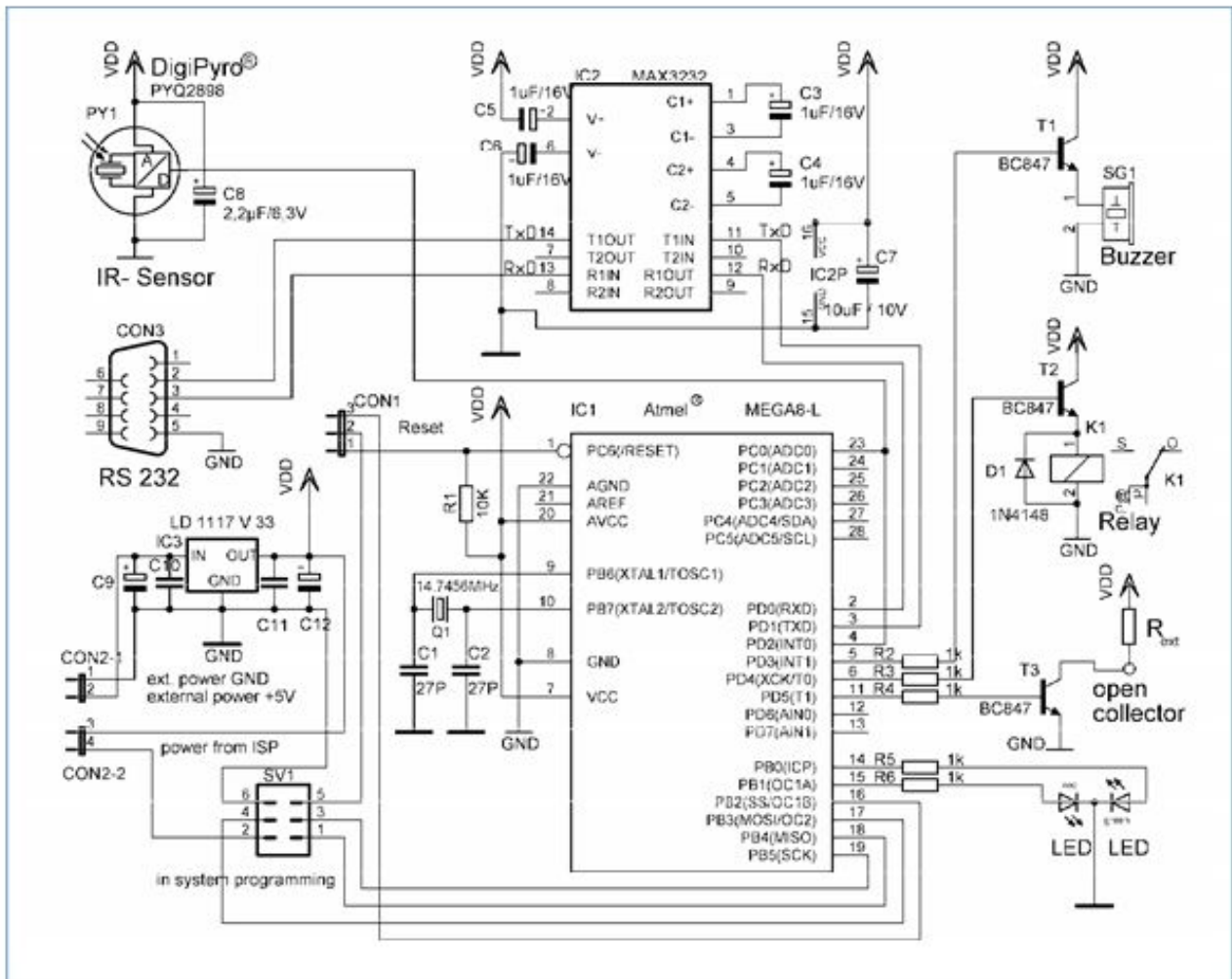

Fig.7: Application circuit example

The above circuit shows possible applications for DigiPyro® as alarm with buzzer or LED output, as light switch with relay output, open collector output for general purposes. It uses PYQ 2898 with Atmel processor AtMega8-L and 3.3 V voltage stabilization. In addition RS232 communication interface is provided. The voltage supply to DigiPyro® is buffered by a 2.2 µF capacitor (C8).

Operating and Handling

Handling

Handle the detectors as ESD sensitive devices and protect them from electrostatic discharges. Working areas should be conductive and grounded. When handling detectors, operators shall be grounded. Avoid mechanical stress on the housing and especially on the leads. Be careful when cutting or bending leads to avoid damage. Do not bend leads less than 5 mm from their base. Do not drop detectors on the floor. Avoid touching the detector window. To clean windows, only use ethyl alcohol with a cotton swab when necessary. Do not expose detector to aggressive detergents such as Freon, trichloroethylene, etc.

Soldering conditions

For the soldering of the detectors within PCBs, the typically applied and recommended process is wave soldering. The soldering temperature should not exceed 285°C with a maximum exposure time of 5 seconds. During the automatic wave solder process we strongly advise to restrict preheating when the detector is directly exposed to the radiation of such heaters. In this case, the detector should be protected from the heat. Manual soldering is also possible when maintaining similar temperature profiles. Reflow soldering is not possible due to the high temperature profiles of the process.

Product Safety & RoHS

Modern high-tech materials are applied in the production of our pyroelectric detectors. Some of these materials are sensitive to high temperature exposure or to specific forms of stress. Our parts are compliant with environmental regulations as can be reviewed on the Excelitas website. We recommend checking always your local regulations. Disposal shall only be carried out in accordance with the latest legislation and directives. In Europe, WEEE directives must be followed.

The leads of these detectors have been pre-tinned with lead-free tin process and may be applied through lead-free solder processes. As such the detector will enable the design of RoHS compliant products.

Performance Advice

Before taking a reading, during testing, and / or operation the unit has to become thermally stable due to its nature as a thermal detector and the high sensitivity of the device. All data are specified at room temperature. When operating at other temperatures within the specified operating range, parameters may vary. The detector might operate outside the quoted range but may have degraded performance.

Frequently Asked Questions

1. **What is the data rate?**
64 Hz typical.
2. **What is the signal range?**
Theoretically 0 to 16383 Counts, in the application depending on the optical system.
3. **Why do I have 8100 digit outputs with no radiation?**
Digital offset / working point.
4. **How often will the Master need to request a signal package?**
Is a 25 Hz sampling rate suitable?
The Master may repetitive request up to 64 times/sec - one request = 1 package.
25 Hz may be insufficient. Recommended value is 64 Hz interrupt driven.
5. **Will I need additional signal filtering?**
Yes: proposed digital bandpass filter 0.2 Hz to 10 Hz (see link). 6.

Does the DigiPyro® offer any cost saving advantages?

Yes, less component requirements, PCB space, assembly work will result in lower system costs.

7. **What is power supply requirement?**
Minimum voltage requirement is 2.7 Volts, maximum 3,6V. Maximum supply current is 15µA. As for any digital device the switching of gate arrays may cause current peaks. Thus a buffering capacitor of 2.2µF is recommended. The microcontroller should be supplied with the same voltage level as the DigiPyro®.
8. **What are the advantages of DigiPyro® compared to analog version?**
 - Better supply voltage rejection of disturbances
 - No analog signal processing
 - No RF interference problems
 - User defines signal processing, filtering, threshold detection and / or envelope evaluation
 - Higher reliability for the complete system
9. **After power is applied how long before accurate reading can be obtained from the device?**
 - a) The internal A/D- converter needs $t_{REP} = 14$ ms to convert a value.
 - b) The detector has to reach thermal equilibrium with the environment. This can take a few seconds to achieve accurate readings, which is typical for all thermal sensors.
10. **There appears to be a maximum rate but no minimum rate for Master Reads.**
Yes, there is no minimum read rate.
11. **What is the sampling rate?**
Recommended sampling rate is 64 Hz interrupt driven by an ascending slope of the *DIRECT LINK* interface. It may be reduced by the hosting µC.
13. **Why is the output not at zero, when there is no radiation?**
The pyro elements provide positive and negative signals. For that reason the base line is set to the mid value of the dynamic range (approx. 8200 Counts). This digital offset represents the zero line.
14. **What is the content of a data package?**
A package consists of a 'data word ready' signal (=high). After detecting this signal, the microcontroller has to wait for min. 25 µs setup time. The microcontroller then reads 42 Bits. Data arrives with MSB first. The reading procedure is defined at *Data Communication* in this note.
15. **How do I handle interrupts, without corrupting data?**
The sensor only updates the data in the *DIRECT LINK* interface, while it is at low level for more than 512 system clock cycles.
There is no update, if *DIRECT LINK* line is kept at high level.
If the controller has to serve an Interrupt, set the *DIRECT LINK* line "high" for the duration of the interrupt. When coming out of the interrupt routine, release it and read the value/Bit. Continue reading as normal.

16. Output of the sensor: Is there a need for pull-up or may the sensor directly be hooked to the computer pin?

The DigiPyro[®] can be hooked directly to a digital I/O- pin of a microcontroller (for example an Atmel[®] Mega8L). But the μ C must be able to drive the pin to High and Low. With some μ C's it might be necessary to have a pull-up resistor in the 20 k Ω range, if the μ C has problems to push the pin to High (the DigiPyro[®] input current is typ. 100 μ A).

17. How to read the data output of PYQ 2898 by using an μ C I/O port?

It should not be a problem to use an I/O- Pin directly (e.g. Atmel[®] Mega 8L μ C). The typical push/pull- current of the DigiPyro[®] is 100 μ A. This is enough for μ Cinput- impedance higher than 20 kOhms.

Please check the output voltage with an oscilloscope. Does the voltage drop to Low too? If the DigiPyro[®] were not able to produce a High, a pull- up resistor in the 20 kOhm- range will help. But most probably it is a communication problem/timing problem rather than a problem with the voltage levels.

To fully profit from the low noise level, it should be read interrupt driven.

18. Why should I read the the data from the Triple Channel DigiPyro[®] interrupt driven?

To fully benefit from the low noise performance of the device, we recommend to read the Triple Channel DigiPyro[®] synchronous as soon as the ADC has finished a conversion. The easiest way to do this is to call the readout routine from an interrupt routine. Therefore the input of the μ Processor should be connected to an interrupt line too.

A raising slope on the *DIRECT LINK* interface should be used to trigger the interrupt. The interrupt line has to be disabled then while reading the data.

19. Summary: The procedure to read the data from the DigiPyro[®]

1. You should trigger an interrupt with the detector pulling the *DIRECT LINK* interface high or alternatively wait for a high signal.
2. Then wait for 25 μ s.
3. Drive the line low for at least $t_L = 200$ ns, then pull it high for at least $t_H = 200$ ns, then release it to read (high impedance).
4. Then the detector will give the first Bit (MSB) to the output.
5. Depending on your input capacitance, you have to wait with reading until there is a saturation of the output (otherwise you will read a high):
6. Wait for at least $t_{bit} = 1\mu$ s (for 10 pF on your input line, for higher C wait longer) to allow the line to discharge your input capacitor.
7. Read the Bit.
8. Repeat this (step 3 to 8) until all 42 Data Bits are read.
9. Then drive it low for at least $t_L = 200$ ns, then release it (high impedance).
10. After the conversion time of the ADC $t_{REP} = 512$ clock cycles (14 ms for Triple) wait for the detector pulling the *DIRECT LINK* interface high (step 1) and read the next 3 values by repeating this procedure from the start.

North America Customer Support Hub
Excelitas Technologies
 22001 Dumberry Road
 Vaudreuil-Dorion, Québec
 Canada J7V 8P7
 Telephone: +1 450-424-3300,
 (+1) 866-574-6786 (toll-free)
 Fax: +1 450-424-3345
 generalinquiries@excelitas.com
 www.excelitas.com

European Headquarters
Excelitas Technologies
 Wenzel-Jaksch-Str. 31
 65199 Wiesbaden, Germany
 Telephone: (+49) 611-492-247
 Fax: (+49) 611-492-170

Asia Headquarters
Excelitas Technologies
 47 Ayer Rajah Crescent #06-12
 Singapore 139947
 Telephone: (+65) 6775-2022
 Fax: (+65) 6775-1008

EXCELITAS
 TECHNOLOGIES

For a complete listing of our global offices, visit www.excelitas.com
 ©2011 Excelitas Technologies Corp. All rights reserved. The Excelitas logo and design are registered trademarks of Excelitas Technologies Corp. DigiPyro[®] is a trademark of Excelitas Technologies Corp. or its subsidiaries, in the United States and other countries. All other trademarks not owned by Excelitas Technologies Corp. or its subsidiaries that are depicted herein are the property of their respective owners. Excelitas reserves the right to change this document at any time without notice and disclaims liability for editorial, pictorial or typographical errors.
 600200_2 APP0208