

BASIC STEPS

# Connecting and Using Infrared Optoelectronics

This application note is intended to assist someone with little or no experience in connecting basic optoelectronic assemblies. A basic optoelectronic sensor assembly consists of two separate components. The first component that must be considered before making electrical connections is the LED, which is called the “emitter” and which will typically emit infrared light. The second is the phototransistor which is called the “sensor” or “detector” and which responds to the infrared light. To ensure good photo-coupling between the emitter and detector, it is recommended the user consider using a standard Optek assembly. The Optek OPB815WZ is a very good example of an Infrared Slotted Switch and will be used in this example.

The first step when connecting the sensor assembly is to provide appropriate power to the LED which is why it is important to understand two key characteristics of the LED. These are the **forward voltage** ( $V_f$ ) and **forward current** ( $I_f$ ). The forward voltage is the minimum voltage required to turn on the LED. This will change depending on the desired forward current and ambient temperature. For gallium aluminum arsenide LEDs,  $V_f$  typically will be 1.2 to 1.3 volts DC @  $I_f = 20\text{mA}$ , as seen in the forward current curves in Fig. 1. The forward current

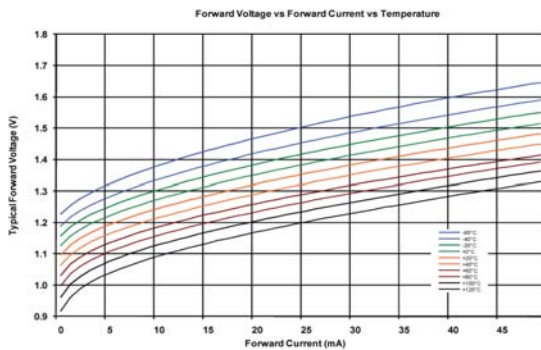

Fig. 1 Typical curve shown for  $G_xA_LA_S$  LED

will determine the amount of power emitted by the LED. The

datasheet will specify the range of forward current that can be safely used without causing damage to the LED. Typically, the forward current will be set at 20 mA. The forward current can be controlled by placing a current limiting resistor in line with the power supply and the LED as shown in Fig. 2.

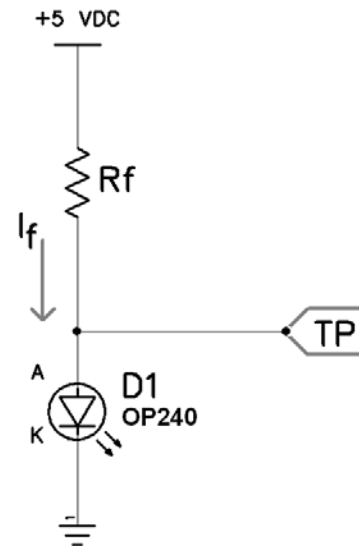

Fig. 2

In our example of the OPB815WZ, the LED used inside is an OP240. We will plan to drive the LED at 20mA at room temperature (20°C). We can obtain the typical forward voltage for this LED by looking at the  $V_f$  curves shown in the OP240 data sheet and at the end of this article. Alternatively, the user can obtain the forward voltage from the datasheet of the OPB815WZ. We see that we can expect to have a nominal  $-V_f$  value of 1.3 V. Because the supply voltage is 5V, we must drop 3.7 V across the resistor,  $R_f$ . Using Ohm’s Law,  $E=I*R$ , we can calculate the resistor to be 185 Ohms. The power being dissipated by the resistor is  $I^2*R$  or 74 mW. Therefore, a 1/8 Watt resistor or larger will work in this application.

As seen in Fig. 2, the positive voltage source will be connected through the resistor to the anode (A) while the cathode (K) is connected directly to ground. Alternatively, the voltage source can be connected directly to the anode, and the cathode can

be connected through the resistor to ground. The anode can be easily identified on the LED as it is usually the longer of the two leads. Or, in the case of an Optek assembly with wires such as the OPB815WZ, the anode will typically be the red wire and the cathode will be the black wire. Before making connections, verify the pin outs by checking the data sheet of the particular LED or assembly that you are using. To verify the connections, measure the voltage at TP to ground and confirm it is 1.3 V. If it measures 5 V, the LED is open or backwards, or there is a wiring problem. If it measures 0 V, the LED is shorted or there is a wiring problem

Now that the LED is connected properly and emitting infrared light, the phototransistor is to be connected so that it can detect the light. The current conducted by the phototransistor will be proportional to the incident light shining on it. The phototransistor functions like a standard transistor except that the base current is produced via an integral photodiode. Because of this, most phototransistors only have two leads – the collector and the emitter. In our case we are looking at connecting the phototransistor half of the OPB815WZ. The datasheet for this assembly tells us that the minimum  $I_{c(on)}$  of the device will be  $3.5\text{mA} @ V_{ce} = 5\text{V}$  when the input LED is driven at  $I_f = 20\text{mA}$ . It also tells us that the saturation voltage ( $V_{SAT}$ ) of the assembly is 0.4 volts maximum. We now have the information needed to calculate the load resistor  $R_L$  value that will be required to give a well-defined change in output voltage when an object passes through the slot of the OPB815WZ. We can calculate this value by the following formula:

$$R_{c(min)} = (V_{cc} - V_{sat}) / I_{c(on) \text{ min.}}$$

For the OPB815WZ, the minimum  $I_{c(on)}$  value is 3.5mA. Substituting this into our formula gives:

$$R_L(min) = (5 - 0.4) / .0035\text{A} = 1.3 \text{ Kohms}$$

Because of several factors, we will want to use a higher value of  $R_L$  than the initially calculated value of 1.3 Kohms. These factors

are:

- LED degradation over time. Allow for a reduction of 20% @ 10K hours of operation.
- LED power output reduction at higher temperatures (when applicable). Allow for a reduction of 25% @  $T_A = 60\text{C}$  (for example).
- Minimum  $I_{c(on)}$  value on datasheet is measured at  $V_{ce} = 10\text{V}$ , but we are operating at  $V_{ce} = V_{sat}$ . Allow for a 20% reduction @  $V_{ce} = V_{sat}$

Taking all of these factors into account gives us a new recommended  $R_L$  value:

$$R_L \text{ (recommended)} = 1.3\text{K} / 0.8 / 0.75 / 0.8 = 2.7 \text{ Kohms}$$

The completed circuit for the OPB815WZ will look like the circuit diagram in Figure 3 below.

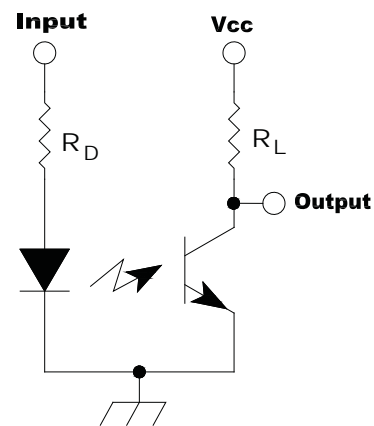

Fig. 3

When connecting a phototransistor, you will see both wire leads are usually of equal length on a single component. The collector and emitter are identified by the packaging around the sensor. For axial leaded Optek components, the collector is typically the lead nearest the flat on the package. On an Optek assembly with wires such as the OPB815WZ, the collector is typically the white wire and the emitter is the green wire. Again, verify the

---

pin outs by checking the data sheet of the particular detector or sensor assembly that you are using. Using the RL value we have calculated, the voltage measured at the Output will go from less than 0.4 V with the LED on (and unblocked) to more than 4.6 volts with the LED off, or blocked by an opaque object.

There are many other factors that may be considered when designing with infrared optoelectronics including aperture sizes, amount of ambient light present, switching speed and more. For a more in depth look, please refer to Optek Application Bulletin 213.

TT electronics OPTEK Technology  
1645 Wallace Drive  
Carrollton, TX 75006 USA  
Tel: +1 972 323 2200  
Fax: +1 972 323 2396  
sales@ttelectronics-na.com  
optekinc.com